



Detect Elevation Defects

The Model 4010 Crease and Lump™ Detection Technology is designed to detect creases, lumps, splices, and other types of elevation defects in moving webs of material. Because of their mechanical construction and operating principles, these detectors can be used in a wide variety of web inspection applications.

Monitor All Materials

Choose the Model 4010 Crease and Lump™ Detector for on-line monitoring of metallic and nonmetallic papers, plastics, foils, films, textiles, and other types of web manufactured materials. As elevation defects are encountered, an inspection roller in the device momentarily loses contact with the web material allowing light to reach a photocell for defect detection and subsequent control of processing equipment.

Automatically Adjust To Changes

Sensing heads in the Model 4010 Crease and Lump™ Detector use rolling contact, and minimal contact force, to prevent damage to the web material during inspection. Each sensing head is self-compensating and self-aligning allowing the detector to automatically adjust to changes in the type or caliper of web material.

					
TECHNICAL SPECIFICATIONS					
Defects Types Detected:	Creases Lumps Splices Wrinkles Other Elevation Defects				
Minimum Detectable Defect:	0.001" (0.025 mm)				
Sensitivity:	Continuously Adjustable				
Sensitivity Range:	100 to 1				
Web Material Texture:	Smooth				
Inspection Increments:	6" (15.24 cm) per Head Unit Each Containing 2 Roller Type Light Gates 3" (7.62 mm) Long				
Contact Head Pressure:	2 ounces/linear inch (2 grams/linear millimeter)				
Maximum Web Speed:	1,000'/min. (304.8 m/min.)				
Outputs:	<table border="0"> <tr> <td style="padding-right: 20px;">Standard:</td> <td>Audio/Visual Alarm 9-12 VDC Pulse Reject Control Output Edge Marker Output</td> </tr> <tr> <td>Optional:</td> <td>Counters Microcontroller Based Display</td> </tr> </table>	Standard:	Audio/Visual Alarm 9-12 VDC Pulse Reject Control Output Edge Marker Output	Optional:	Counters Microcontroller Based Display
Standard:	Audio/Visual Alarm 9-12 VDC Pulse Reject Control Output Edge Marker Output				
Optional:	Counters Microcontroller Based Display				
Illumination:	Fluorescent Light Sources				
Ambient Temperature:	40 to 160° F (4 to 70° C)				
Power:	120/220/240 VAC 50/60 Hz Single Phase				
<small>Specifications are subject to change without notice</small>					



R.K.B. OPTO-ELECTRONICS, INC.

6677 Moore Road • Syracuse, New York • 13211 • United States of America
 Tel: +001-315-455-6636 • Fax: +001-315-455-8216 • Email: sales@rkbopto.com
 Internet: www.rkbopto.com / www.webinspection.us / www.hole-detection.com

Model 4010 Crease and Lump™ Detection Technology

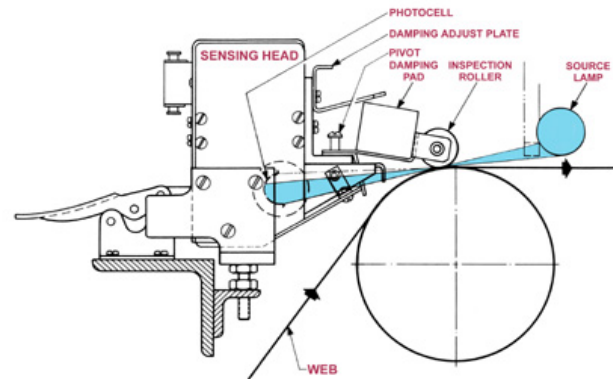
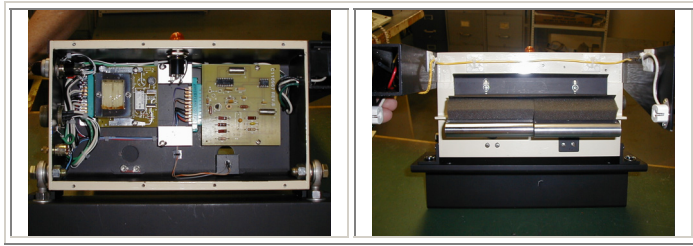

Span Any Web

The Model 4010 Crease and Lump™ Detector use modular sensing heads with two three inch long rollers to provide a six inch wide inspection capacity. These sensing heads can be combined, side by side, to span any web width required for your application.

Demand Proven Performance

The Model 4010 Crease and Lump™ Detection Technology has been designed for stable and reliable operation under real world conditions found in various low, high and ultra-high-speed coating, laminating, printing and other various conversion processes where elevation defect detection is required. Their performance is well established and proven in various installations worldwide.

Call RKB

Call us to discuss your crease detection requirements and to learn more about the industry's most cost effective and reliable detector in the world.

Add Analysis and Reporting

Repeating defect detection and defect size classification capabilities are included with each Model 4010 Crease and Lump™ Detector. Our QAMS® Quality Assurance Management System software can also be added to the system to provide:

- Analysis and Charting
- Footage Tracking
- Product Code Identification
- Material and Process Traceability
- Real Time and Historical Reporting
- Status and Parameter Displays
- On-Line Diagnostics

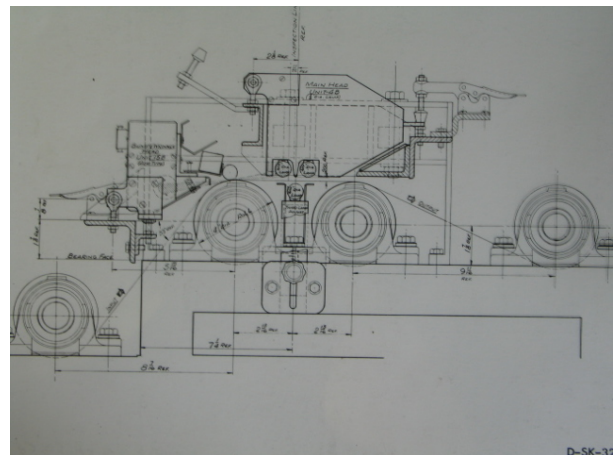
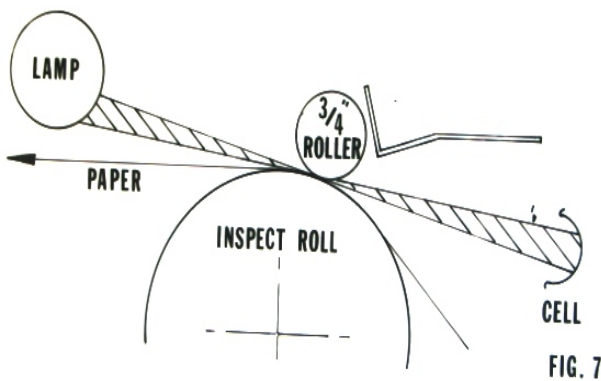

R.K.B. OPTO-ELECTRONICS, INC.

6677 Moore Road • Syracuse, New York • 13211 • United States of America
Tel: +001-315-455-6636 • Fax: +001-315-455-8216 • Email: sales@rkbopto.com
Internet: www.rkbopto.com / www.webinspection.us / www.hole-detection.com